

FloCheck Dissolve

Bi-directional inflow control valve with temporary checking function in injection direction

FloCheck Dissolve provides a temporary checking mechanism allowing injection of fluids/acid stimulation after setting the liner. Full-bore access is regained once the checking mechanism disappears over time.

TAQA's FloCheck Dissolve valve acts as a passive ICD, and consists of a neutrally buoyant thermoplastic ball and dissolvable material cage, in addition to the standard passive device nozzle of required size.

The cage and ball create a check valve function when circulation is required after screen installation, for fishbones drilling, acid stimulation and breaker pumping among other applications. It is integral that fluid compatibility with the cage is confirmed to enable the FloCheck Dissolve valve to function correctly.

The valve acts as a passive ICD in the production direction in both scenarios, before and after cage vanishes.

The time period which the cage is expected to dissolve is based on the fluids present in the well and the bottom-hole temperature.

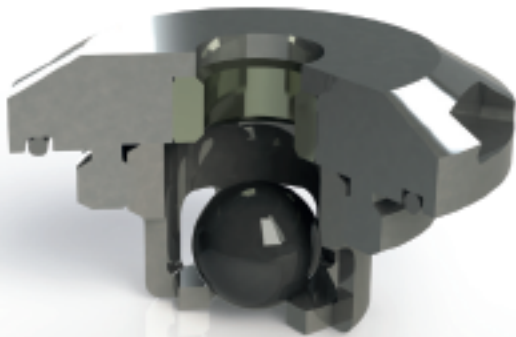

FloCheck Dissolve

Features

- Can be run in conjunction with TAQA's portfolio of sand screens
- Incorporates an initial check valve function
- Dissolving cage and thermoplastic ball will completely disappear over time

Benefits

- Allows for powering of fishbones, motors and other devices
- Allows stimulation and/or injection
- Interchangeable with all TAQA inflow and outflow control devices
- Dissolves over time, allowing full-bore access

Technical Specification

Nozzle size	4-10mm
Valve port	Standard TAQA M33
Pressure rating	5,000psi (344bar) - thermoplastic ball
Static seal rating	5,000psi (345bar) - valve body O-ring
Cd value (with cage)	0.83
Cd value (without cage)	0.96